

Portland® GLASS FIRESCREENS

Installation Instructions

SAVE THESE INSTRUCTIONS

Read all of these instructions before installing or using your Portland Willamette firescreen.

This product is intended only for installation in a masonry fireplace constructed in accordance with the requirements of the Standard for Chimneys, Fireplaces and Vents, NFPA No. 211, or applicable local code requirements.

WARNING: This fireplace screen has not been tested with a mantel. Fireplaces with mantels must be constructed under National Fire Protection Association Publication 211, paragraph 73.3.3.

The Portland Willamette firescreen was designed for use in rectangular fireplaces. It is not recommended for use on only one side of a "see-thru" type fireplace (a fireplace with openings on opposite sides in two different rooms), as the resulting unequal draft conditions which occur may direct flames and heat directly against the firescreen. This direct heat and the flames may be sufficient to scorch your firescreen's finish and darken, or even break, the glass panels. If firescreens are used on both openings, it may be possible to equalize the drafts by adjusting the damper setting on each firescreen. The firescreen or glass is not warranted against damage when used on only one side of a "see-thru" fireplace.

IMPORTANT: Hydrochloric (muriatic) acid is often used by builders to clean excess mortar from new fireplaces. The fumes from this acid are highly corrosive and will damage the finish of your fireplace equipment unless neutralized. This corrosive action can last for many years if not neutralized. To neutralize, wash masonry with ammonia water and rinse thoroughly with clean water. Any acidic or caustic material used around your fireplace can damage the finish of your firescreen. This includes some mortars or sealants that may be used to install and seal firescreens and some paints used on fireplace faces. Portland Willamette assumes no responsibility for these damages.

Firescreen Installation.

Tools required for easiest installation:

- | | |
|----------------------|-------------|
| Blade screwdriver | Gloves |
| Phillips screwdriver | Scissors |
| Pliers | 3/8" wrench |
| 1/16" wrench | |

A 5/16" masonry drill, drill motor and hammer may be required for your installation—see instructions, steps #7 and #8;

- Carefully stand the firescreen up with its front against a wall—use a soft, clean cloth between the firescreen and the wall to protect both from damage.
Remove rubber stops on inside of door frame behind door handles.

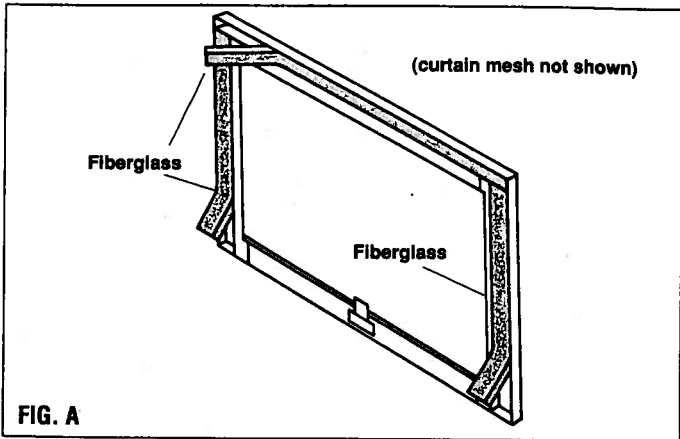
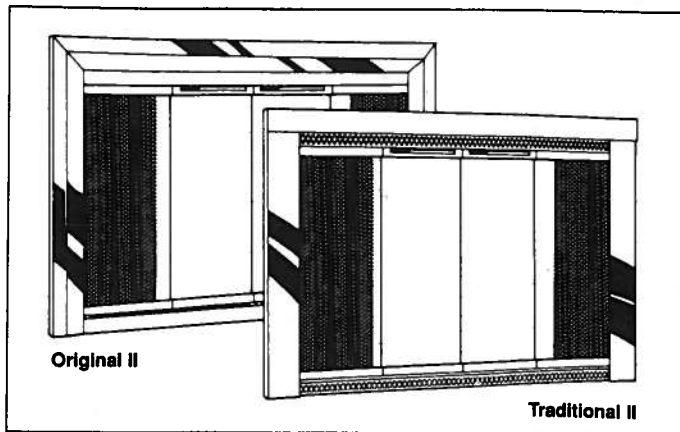

- Fig. A: Measure and cut, using scissors, the strip of included fiberglass insulation into three pieces to fit into both of the side bars and into the top bar of the firescreen, as shown. NOTE: Avoid contacting the fiberglass with your bare skin as it may cause some irritation—always wear gloves when handling fiberglass.

WARNING: Fiberglass insulation must be installed to not only seal the firescreen to the fireplace face but to also protect the firescreen finish from heat damage. Fiberglass insulation must be installed before mounting screen.

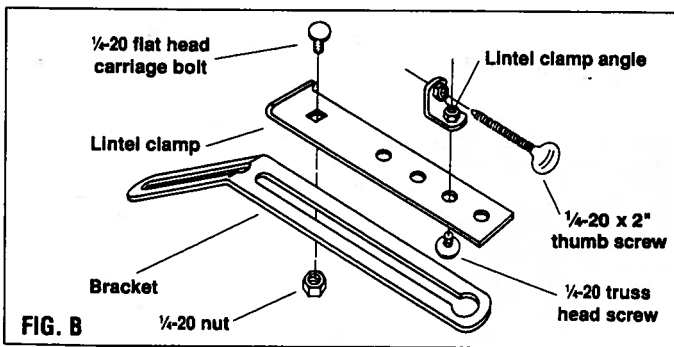

- Fig. B: Assemble the two lintel clamps as follows:
 - Install a 1/4-20 x 2 thumb screw into each of the lintel clamp angles shown.
 - When assembled, the lintel clamp and angle assembly must be able to securely grip the lintel bar inside your fireplace, as shown in Fig. E. Assemble a lintel clamp and a lintel clamp angle together—insert a 1/4-20 x 1/4 truss head screw through one of the four holes in the lintel clamp and into the lintel clamp angle and tighten—use whichever of the four holes as necessary, depending on the width of your fireplace's lintel bar.
 - Place the lintel clamp and angle on top of a bracket, as shown. Fasten together with a 1/4-20 x 1/2 flat head carriage bolt, inserted through the square hole in the lintel clamp and through the bracket as shown, and a 1/4-20 nut—do not tighten more than finger-tight at this time.

d) Repeat steps b) through c) for the second lintel clamp assembly.

If mesh panels make it difficult to install mounting brackets, large mesh rings attaching mesh to upper slide rod bracket and lower retaining bracket may be disengaged from those brackets. Simply slide rings over the brackets and move mesh panels out of the way. Remember to reinstall large mesh rings over retaining brackets when installation is complete, to hold mesh panels in place.

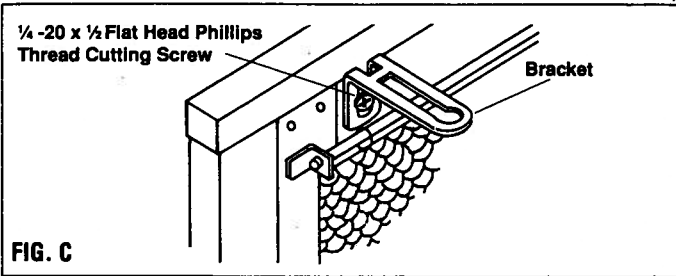

FIG. C

4 Fig. C: Attach the two completed lintel clamp assemblies (from step 3) to the firescreen upper mounting holes with 1/4-20 x 1/2 flat head phillips screws already factory installed in those holes, as shown. Do not tighten at this point. Bracket can be bent down or up to fit individual mounting situation to clear fireplace lintel.

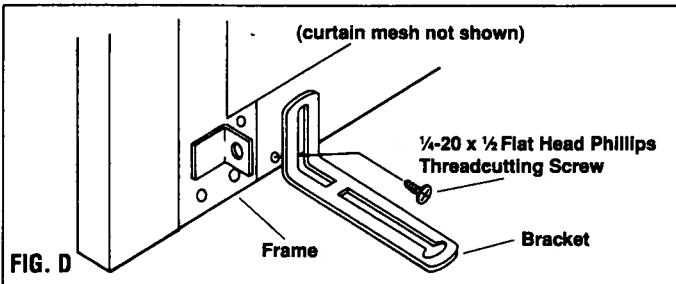

FIG. D

5 Fig. D: Attach the two remaining brackets to the firescreen at the bottom, on each side, with 1/4-20 x 1/2 flat head phillips screw into the bottom mounting hole in the firescreen frame, as shown. These screws are already factory installed, so remove to attach brackets.

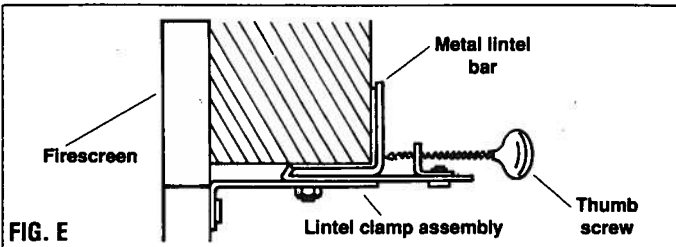

FIG. E

6 Fig. E: Attach the firescreen to the fireplace as follows:

- Fit the firescreen to the fireplace opening with the lintel clamp assemblies and brackets inside the fireplace (these may have to be adjusted in order to clear the fireplace opening). Bend bracket to fit.
- Position the two upper lintel clamps and tighten the thumb screws to securely grip the metal lintel bar inside your fireplace as shown. Ensure that the firescreen is flush against the face of the fireplace and tighten all upper screws.

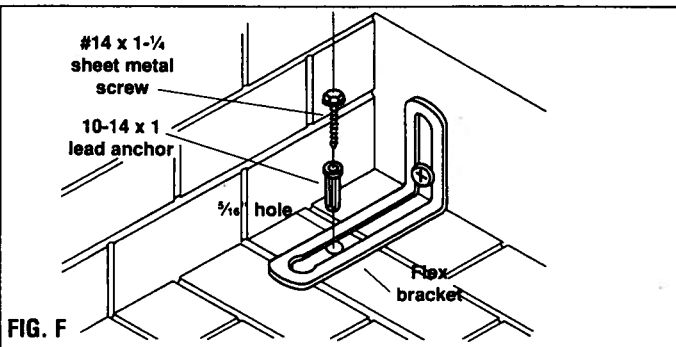

FIG. F

7 Fig. F: The bottom of the firescreen should rest on the hearth outside the fireplace. If the hearth does not extend out far enough to support the bottom of

the firescreen you will need to secure the bottom of the firescreen. This is done by attaching the lower brackets to the floor (shown) of the fireplace—follow the instructions below. Otherwise, adjust the lower brackets as needed until they rest on the floor of the fireplace and leave unattached.

8 Fig. F: Secure the bottom of the firescreen as follows:

- Drill two holes, using a 3/16" masonry drill, about 2" deep into the floor of the fireplace—determine suitable locations for each hole by using the two lower brackets (from step 5), attached to the firescreen (one hole required per bracket). Mark the hole locations and move the brackets out of the way before drilling the holes.
- Next, gently tap a 10-14 x 1 lead anchor into each of the two holes you have drilled (one anchor in each hole) using a hammer.
- Move the brackets back into position over the holes and insert a #14 x 1-1/4 screw into each hole to secure the brackets.
- Make certain sides of firescreen are parallel and that the frame is not slightly twisted when mounted. If sides are not parallel, doors will not align properly when closed. If either door pulls away from the top or bottom of the frame and does not line up with the other door, adjust frame by loosening bottom mounts and slightly pulling out on frame at the bottom left or bottom right until doors line up with each other and the frame. Retighten bottom mounts.

NOTE: For fireplaces other than standard configurations or constructions, consult your dealer for information concerning alternative mounting methods.

9 Some of the fiberglass may have squeezed out from behind the firescreen during installation. Use a thin object, such as a letter opener or knife, to carefully push the fiberglass back behind the firescreen for a neat appearance. Be careful not to scratch or damage the finish on your firescreen.

Damper Operation.

Your firescreen is equipped with upper and lower hidden damper operators located at the top and bottom center of the firescreen, behind the door track. Both dampers can be opened or closed by moving the damper operator - right to open or left to close.

With your firescreen in place, you need not close your fireplace's flue damper as you can simply close the dampers on the firescreen, effectively sealing off the fireplace from the rest of your home. This is not only more convenient, but allows you to let a fire burn out without letting the heat in your home escape up the chimney. Using your firescreen's dampers, in conjunction with your flue damper, you can usually achieve optimum burning and draft conditions for your fireplace to maximize burning efficiency and heat output while reducing or eliminating any smoking problems. Experiment with different flue settings until you find the combination which works best with your fireplace.

Selecting and storing firewood.

The type of firewood you burn and its moisture content can have a large effect on the amount of heat and enjoyment you are able to obtain from your fireplace. The following are some general guidelines for selecting and storing firewood.

Most firewood can be categorized as one of two basic types: softwood or hardwood. Each of these types offers something different in terms of heat value, flame size, burning duration and aroma.

In general, softwoods are from trees that do not lose their leaves or needles, such as pine, fir, hemlock, and spruce. This type of wood ignites readily, burns rapidly, and produces a crackling blaze. However, softwoods also tend to leave soot and residue in your chimney and, if used often, may require more frequent cleaning of your chimney (see CREOSOTE—FORMATION AND NEED FOR REMOVAL). Hardwoods, in general, are from trees that lose their leaves in the fall, such as oak, walnut, maple and cherry. Most hardwoods burn relatively slowly and quietly, and leave little residue and soot in your chimney. However, most hardwoods are often difficult to split and ignite. Some types of hardwoods, such as birch, are almost as easy to split and ignite as softwoods, yet are long-lasting and clean-burning like most hardwoods and are a good, overall choice.

If both hardwoods and softwoods are used for burning, use the softwood to start your fire, then add the hardwood as needed. This will result in a fire that is both easily started and long-lasting. If just one type of wood is to be used, hardwoods are preferred over softwoods due to their greater heating and burning efficiency.

In order to obtain the best heating and burning efficiency from your fireplace, only burn wood that has been properly seasoned, with a moisture content about 22% to 24%. The moisture content of freshly cut wood depends on many factors, such as the type of tree, the time of year and whether the tree was living or dead, but can usually be assumed to be greater than about 34%. Therefore, in general, most wood should be dried before attempting to burn it.

The surest way of ensuring that your wood is dry enough is to buy or cut it six to eighteen months before you intend to use it. It should be cut into lengths about 18 to 20" long and split into pieces with diameters no larger than about 10". After splitting, the wood should be stacked outside, under a roof or with a cover to protect the wood from getting wet, using skids to keep the wood off the ground. The wood should be stacked in such a manner that air can circulate between the pieces.

It is possible to dry wood too much, as wood with a moisture content below about 18% doesn't give off very much heat when burned. Also, some wood may need to be dried for a longer period, especially if the wood is waterlogged (soaked in water for a period of time). Never burn wood that has been treated with creosote, such as pilings, telephone poles, fence posts or railroad ties, as the creosote will burn at a much higher temperature than your fireplace was designed for and could easily start a chimney or roof fire. Burning creosote gives off large quantities of pollution and the smoke is especially foul-smelling and unpleasant.

Building a fire.

WARNING: Never use gasoline, gasoline-type lantern fuel, kerosene, charcoal lighter fluid, or similar liquids to start or "freshen up" a fire. Keep all such liquids well away from the fireplace while it is in use.

WARNING: Do not place combustible materials close to fireplace opening.

A properly built fire will maximize the heat output and enjoyment from your fireplace. For best results, use a sturdy grate or wood basket (for good air circulation), placed against the back wall of your fireplace (for maximum heat radiation). Always use at least three logs, as they will radiate heat to each other and help keep the fire burning with minimal attention.

Follow these steps for a quick starting and successful fire:

- 1 Prepare some kindling by splitting wood into pieces no larger than about 1/4" diameter and a few, larger pieces (split about 1 to 2" in diameter). Also, select about three or more pieces of wood about 8 to 10" in diameter (normal fireplace-sized pieces).
- 2 Crumple several sheets of newspaper tightly and place on top of the grate.
- 3 Place all of the kindling on top of the newspaper, crisscross fashion, and then place the slightly larger pieces on top of the kindling, crisscrossed as well.
- 4 Lay one or more crumpled sheets of newspaper on top of the wood inside the fireplace and light (before lighting, ensure that the flue damper is open)—this is to warm the flue and establish a draft up the chimney. While the paper is burning, light the newspaper under the kindling.
- 5 Wait until the kindling and slightly larger pieces have ignited and are burning before adding the normal fireplace-sized pieces of wood. Place the wood in the fire in such a manner that some air can circulate between the pieces, yet the pieces are as close together as possible.
- 6 Close the curtain mesh and keep closed while the fire is burning to prevent any sparks or hot coals from escaping the fireplace. You may also wish to

close the glass doors, but do so only after allowing the doors to warm up and only if the fire is not too large. **The flames of the fire should never be allowed to come any closer than about 8" from the glass doors.**

WARNING: Operate only with both doors fully open or fully closed to reduce risk of smoke and flame spillage.

Smoking may also occur if your home is slightly depressurized, which is when the pressure inside your home is less than the pressure outside. This is most likely to occur in a "tight" home (a home with good weatherstripping, etc.), or if an exhaust fan (such as a fan over your stove or in the ceiling in your bathroom) is operated while a fire is burning. It may be necessary at times to crack open a window or door when using your fireplace, unless some other means of supplying additional air is available, such as a forced-air type heating system which uses an outside air supply.

Avoid building a fire that is especially large or hot. The tempered glass in the doors and the finish on your firescreen should be able to withstand temperatures as high as 550°F without sustaining any damage. Temperatures as high as this or higher are not likely to occur with normal use.

Should a fire become too large or hot, open the firescreen's damper all the way and then open both glass doors all the way—this will quickly reduce the interior heat of the fireplace. For extreme cases, a light spray of water directly on the fire will help to quickly reduce its temperature and size. Use a poker to push the wood to the back of the fireplace and tend the fire until its size is reduced.

WARNING: Never allow any cold objects or water to come into contact with the glass in the doors when hot or breakage may occur.

Disposal of ashes.

Ashes should be placed in a metal container with a tight fitting lid. The closed container of ashes should be placed on a noncombustible floor or on the ground, well away from all combustible materials, pending final disposal. If the ashes are disposed of by burial in soil or otherwise locally dispersed, they should be retained in the closed container until all cinders have thoroughly cooled.

Creosote: Formation and need for removal.

When wood is burned slowly, it produces tar and other organic vapors, which combine with expelled moisture to form creosote. The creosote vapors condense in the relatively cool chimney of a slow-burning fire. As a result, creosote residue accumulates on the flue lining. When ignited this creosote makes an extremely hot fire.

The chimney should be inspected at least twice monthly during the heating season to determine if a creosote buildup has occurred.

If creosote has accumulated it should be removed to reduce the risk of a chimney fire.

Opening and closing fullfold bifold doors

The positive latches at the center top and bottom door tracks on fire-screens with fullfold bifold doors, assure the alignment of the doors and keep these doors from opening if a log should roll against them while closed.

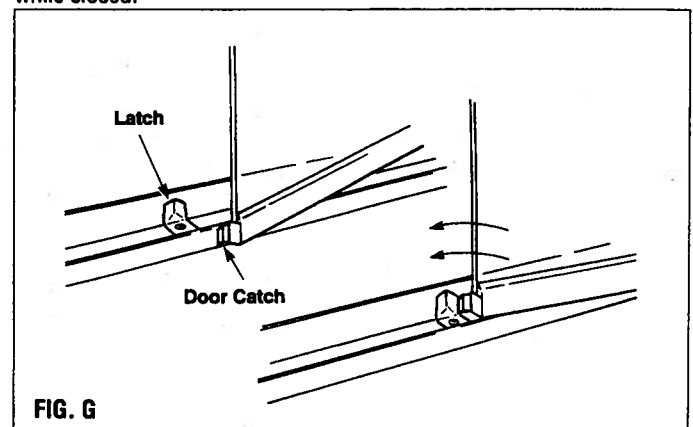

FIG. G

- 1** Fig. G: The door catches at the top and bottom of each door, behind the door trim, will automatically disengage the latches in the door tracks as you open the doors.
- 2** To close the doors, engage the door catches behind both top and bottom door latches. Fully close the bifold door, engaging the spring latch into the top door track, to lock and align the door.

Removal and installation of glass doors - standard bifold or cabinet doors

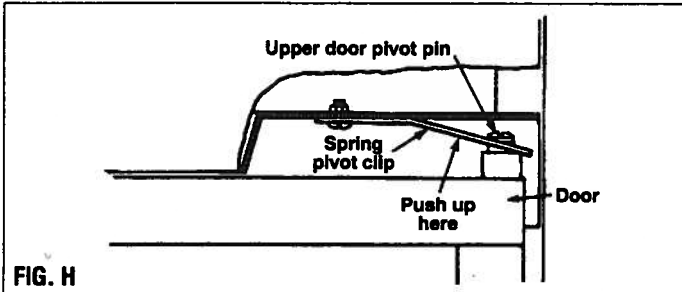

FIG. H

- 1** Fig. H: Open doors so that the doors are almost flat against one another. Reach up into the door track, next to the upper outside corner of the door and push up on the spring pivot clip, next to the pivot pin, releasing the upper door pivot pin.

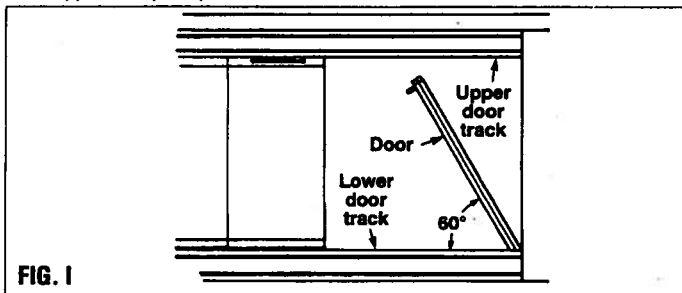

FIG. I

- 2** Fig. I: Pull the top of the door towards the center of the firescreen until the door is tilted about 60°. Lift up on the door - this will release the lower door pivot pin from the door track. Remove the door from the firescreen.
- 3** To reinstall the door, insert the lower door pivot pin into the guide hole in the door track, with the door tilted as shown. Pull the top of the door towards the upper outside corner of the firescreen, with the upper door pivot pin inside the door track, until the upper door pivot pin engages with the upper spring pivot clip. There should be an audible "click" when the pin has engaged.

- 4** Close the doors and ensure that all of the pivot pins are properly engaged so that the doors operate freely.

Removal and installation of glass doors - fullfold bifold doors

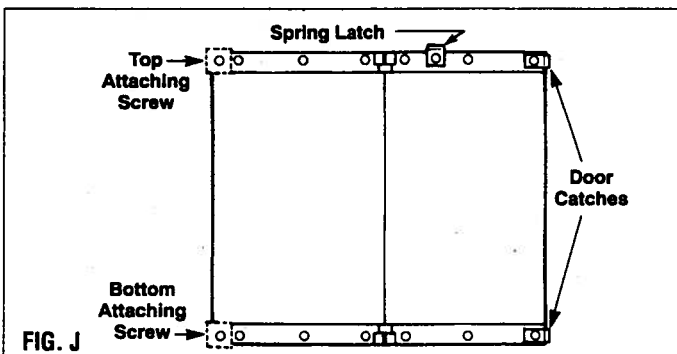

FIG. J

- 1** Fig. J: Open door so panels are fully extended and not folded together.

- 2** Use a Phillips screwdriver to remove top and bottom screw attaching door frame to hinge.
- 3** To install door, align top and bottom door frame-to hinge mounting holes and replace screws. Tighten firmly.

Replacing glass.

Tools required: Phillips screwdriver; Gloves

IMPORTANT: Before attempting to remove the glass doors from the firescreen, ensure that the fire is completely out and both firescreen and glass doors are cooled to room temperature.

NOTE: The glass used in your glass doors is tempered to withstand impact and, if broken, will shatter into many small pieces which may have sharp edges or splinters. Always wear gloves when handling any broken glass.

Replace glass only with Portland Willamette supplied replacement glass. See warranty for ordering instructions.

NOTE: These instructions are to be used if only one glass panel is broken and no door components are damaged. Contact your dealer for a replacement door in all other cases. Use only Portland Willamette replacement glass.

Remove the cooled door from the firescreen as shown in previous REMOVAL AND INSTALLATION OF GLASS DOORS.

Clean up and remove all broken glass from the firescreen, hearth and inside the fireplace. Wear gloves while handling the broken glass to prevent cuts.

Lay the door face down on a flat surface, such as a table, using a soft, clean cloth between the door and the surface to protect each from damage. Ensure that no glass particles get on the protecting cloth or table where they might damage either surface.

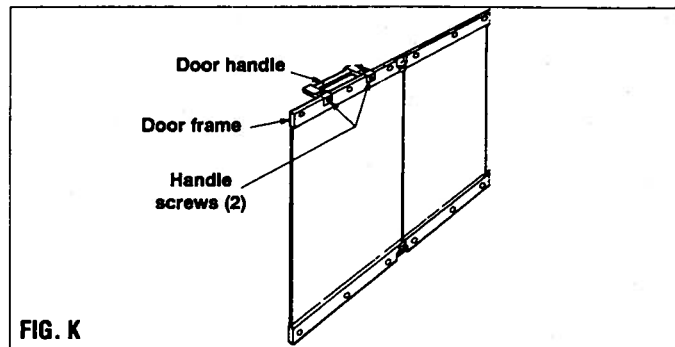

FIG. K

- 1** Fig. K: Remove the two door handle screws and the door handle to allow the door to lay flat on the table. If the broken glass is on the handle side, support the frame while removing the screws to prevent damage to the hinge. Wear gloves to protect your hands from the glass particles which remain clamped in the door frame.

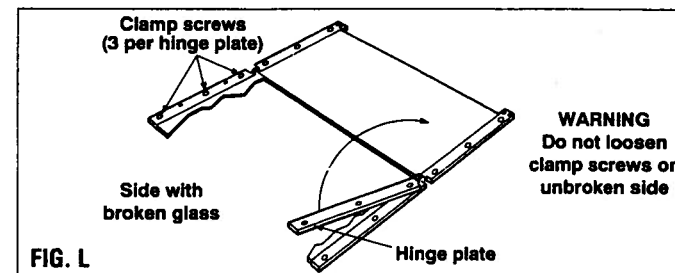
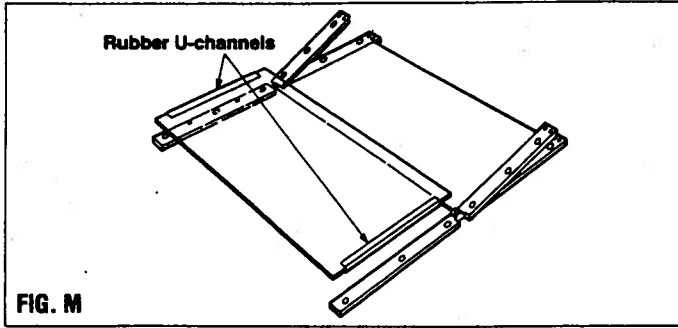
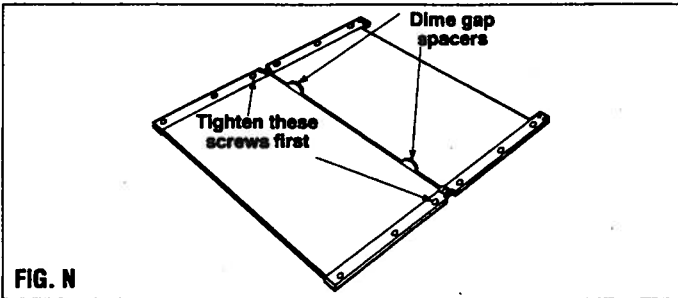

FIG. L

- 2** Fig. L: Remove the six clamp screws from the hinge plates that held the broken glass panel. Fold the hinge plates over on top of the intact door panel. Do not move the loose frame parts until you have identified them so that they will be reassembled in the same position. Dispose of the broken glass and rubber "U"-channels which were released by the clamps.
Warning: Do not loosen the clamp screws which retain the glass on the unbroken door panel. If the door alignment is lost, it will be necessary to prepare for reassembly by cleaning up any remaining glass particles from the work area. The cloth covering the work surface must be free of glass or any other particles which may scratch the finished surfaces of the door.



3 Fig. M: Start with the unbroken door panel face down on the clean cloth. Locate the frame parts back in their correct positions inline with the frames on the unbroken side. Install the rubber "U"-channels centered on the top and bottom of the glass panel. Lay the glass, with the rubber installed, into the frames.



4 Fig N: Fold both hinge leaves over the top of the frames which support the new glass panel. Align the holes and start all six clamp screws. Set the glass to proper glass spacing with two (2) dimes positioned as indicated. Tighten the two clamp screws closest to the hinges. Next, just lightly snug up the other four screws. Recheck and adjust, if necessary, the spacing between the glass panels.

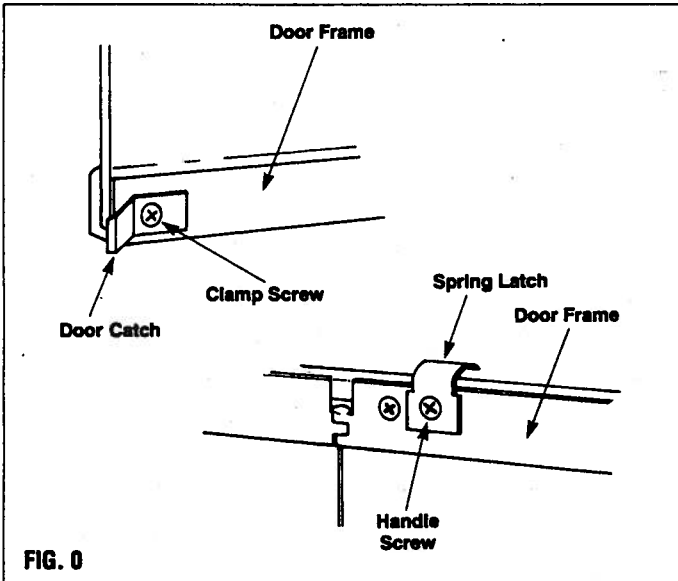
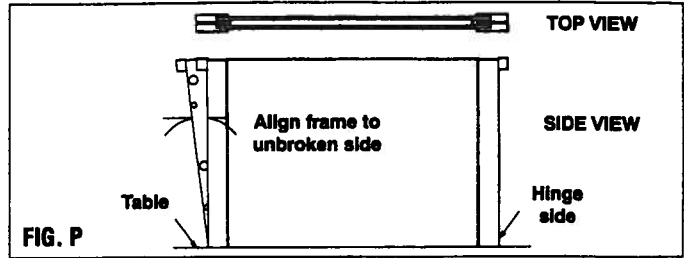

Fig O: With optional full fold bifold doors, make certain to replace and align top and bottom door catches under the clamp screw and the spring latch at top of the door, under its clamp screw.



5 Fig. P: Lift the outside edges of both door panels so they meet straight up in a closed book position. Align the frames holding the new glass panel with the other frames per Fig. M. When the frames are aligned properly, fold the door back flat on the cloth. Tighten the clamp screws and recheck the alignment.

6 Replace two door handle screws and the door handle.

7 Reinstall the doors onto the firescreen as shown in REMOVAL AND INSTALLATION OF GLASS DOORS.

CARE AND CLEANING.

Never use an abrasive polish on the finish on your firescreen—clean with a mild soap solution and a soft cloth, then dry. Use a mild soap solution to remove any stubborn stains from the glass, then follow with a dampened towel, followed by a dry towel. Do not use ammonia or ammonia-based glass or household cleaners to clean the glass or the firescreen, as these types of cleaners may damage the finish of your firescreen. Minor finish scratches can be removed by applying lemon oil. DO NOT CLEAN GLASS WHEN HOT OR BREAKAGE MAY OCCUR.

Firescreen Limited Warranty

The manufacturer warrants to you, the original retail purchaser only, that your firescreen will be free of defects in material and workmanship at the time of your purchase from an authorized dealer or distributor for a period of one year beginning with the date of purchase.

At any time during this stated period, should any of the parts be found to have been defective in material or workmanship at the time of purchase, the manufacturer will repair or replace same at no cost to purchaser. However, purchaser must pay labor and transportation costs for removal and return of the firescreen, or its parts, to the manufacturer, as well as labor costs for reinstallation of the repaired unit. Proof of purchase must accompany the returned product. If you believe the product is defective, notify your dealer who can assist you in returning it to the manufacturer whose address is: Portland Willamette, 6800 N.E. 59th Place, Portland, Oregon 97218.

In the case of breakage of a pane of glass on the firescreen, these are warranted to the original purchaser against breakage for as long as you own the firescreen in the original installation. Portland Willamette's liability under this warranty is limited to replacement, without charge, except for transportation and installation labor, of the glass panels in the event of breakage upon receipt of notice in writing to Portland Willamette or their authorized dealer of such breakage. This warranty shall not apply to any firescreen panel of glass which, in Portland Willamette's judgment has been subject to misuse, negligence or accident.

PORTLAND WILLAMETTE LIMITS THE DURATION OF THE IMPLIED WARRANTY OF MERCHANTABILITY TO THE PERIOD SET FORTH ABOVE, APPLICABLE TO THE PARTS AS SPECIFIED, AND OTHERWISE DISCLAIMS ALL IMPLIED WARRANTIES WITH RESPECT TO THE FIRESCREEN AND ITS PARTS. Some states disallow certain limitations on implied warranties, so you should consult your state law if you have a question regarding this limitation and disclaimer.

The manufacturer disclaims any and all liability for incidental, consequential, special or indirect damages arising out of any claimed breach of warranty or otherwise. However, some states do not allow exclusion or limitation of such damages so this disclaimer may not apply to you.

The remedy provided in this limited warranty for a defective firescreen is purchaser's sole and exclusive remedy subject to your state law. Further, this warranty gives you specific legal rights and you may also have other rights which vary from state to state.

ULTRA FYRE® RADIANT HEAT GAS LOGS

Portland Willamette Ultra Fyre® gas log sets add beauty and practicality to your fireplace. Clean burning logs operate on LP or natural gas. 15" to 60" widths in a choice of finishes. All molded to look like real wood.



See your Portland Willamette dealer for matching Portland Willamette accessories to compliment your new glass door firescreen.

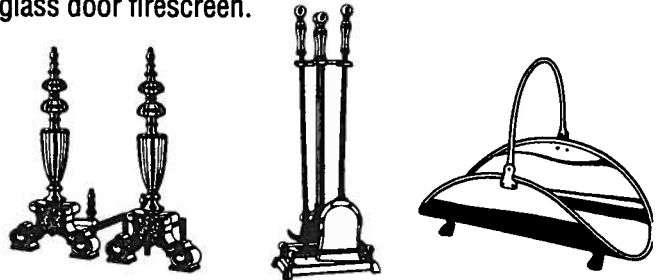

PORTLAND WILLAMETTE

6800 NE 59th Place
Portland, Oregon 97218